

Form 491-010131

Description

The PBSA, PBSB, and PBSC power supplies are designed to work with the Optomux B1 brain board and the Mystic B100 brain board. The PBSC can also be used with the Pamux B5 brain board.

The power supplies are sized appropriately to provide power for the brain board as well as logic power for 16 digital I/O modules. When the PBSC is used with a Pamux B5 brain board, it can also supply power for a Pamux Term1 terminating resistor connected to the B5.

The power supplies mount directly to the appropriate digital I/O mounting racks. The electrical connection is made with two screws to threaded contacts on the digital I/O mounting rack. The brain board mounts directly above (on top of) the power supply.

The PBSC is a 5 VDC power supply that runs on 12/24 VDC. It mounts directly to single-channel racks having a header connector. The power supply connects with two screws to threaded contacts on the rack. The power supply mounting allows an OPTOMUX or PAMUX brain board to be mounted above the supply. The power supply provides sufficient current to power 16 channels of I/O and one OPTOMUX or PAMUX brain board.

The power supply is only for use with standard or G4 modules that use a 5-volt logic voltage, such as ODC5, OAC5, IDC5, IAC5, etc.

The PBSC is ideal for battery-backed applications, such as remote telemetry, remote data logging, and security.

Part Numbers	Description
PBSA	5 VDC Power Supply that runs on 120 VAC
PBSB	5 VDC Power Supply that runs on 220 VAC
PBSC	5 VDC Power Supply that runs on 12/24 VDC

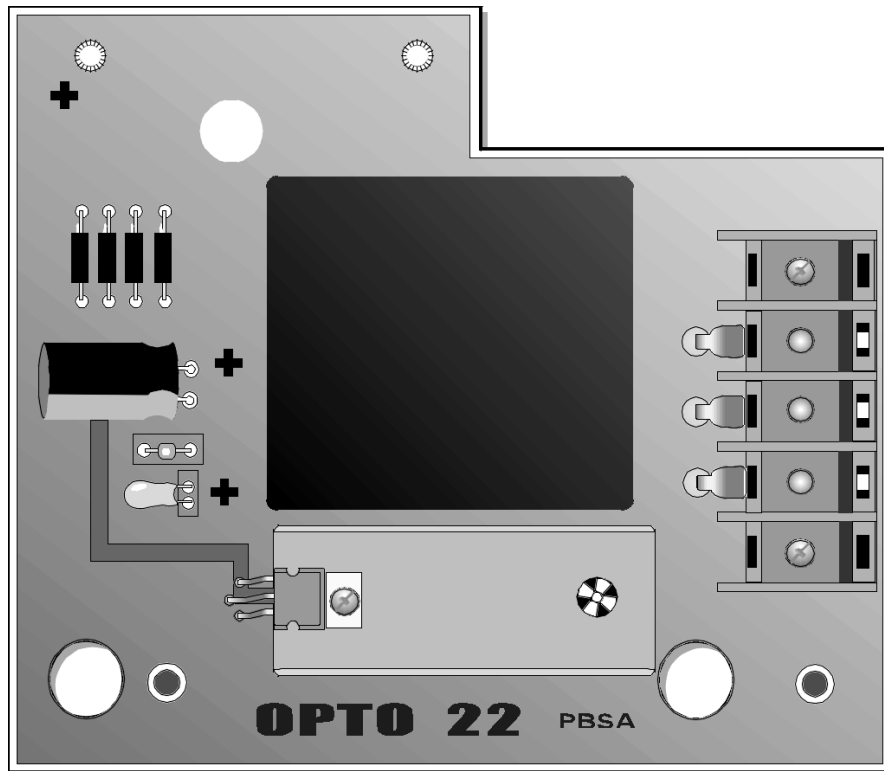

Form 491-010131

Specifications

Model	PBSA	PBSB	PBSC
Input Range	105-125 VAC	200-240 VAC	10-28 VDC
Output Voltage	5 VDC	5 VDC	5 VDC
Output Current	0.5 amps	0.5 amps	1.5 amps
Operating Temperature	-25° to 65° C	-25° to 65° C	-25° to 65° C
Isolation Breakdown Voltage	2,500 VAC	2,500 VAC	500 VAC
Power Dissipation	3-9 Watts	3-9 Watts	3-10 Watts
Humidity (non-condensing)	0-95%	0-95%	0-95%
Compatible Brain Boards	B1 and B100	B1 and B100	B1, B5, and B100
Compatible digital I/O mounting racks (All 3 power supplies are compatible with these racks)	Standard: PB4H, PB8H, PB16H, PB16HC Quad Pak: PB16HQ G4: G4PB8H, G4PB16H, G4PB16HC		

Installation

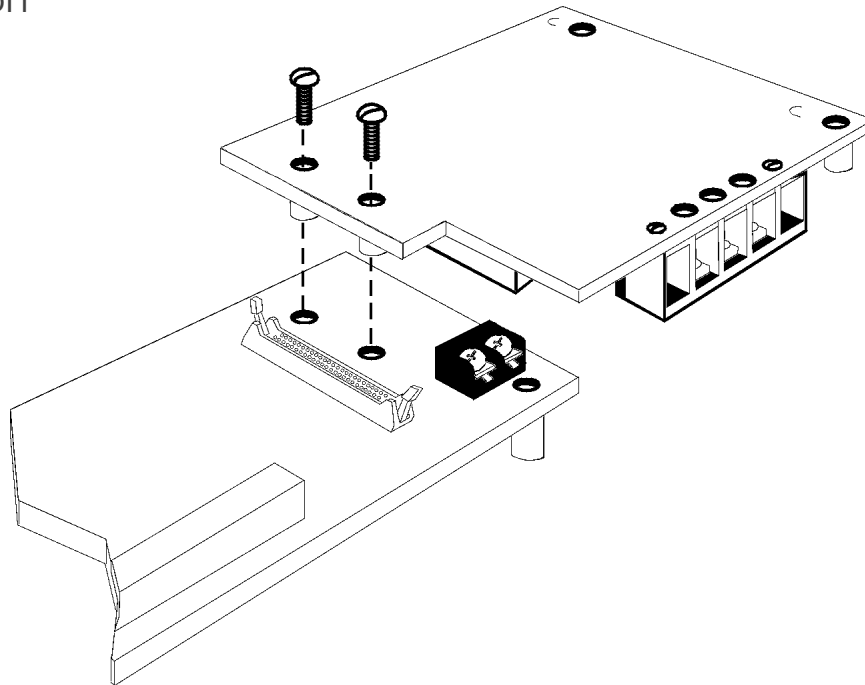

Dimensions

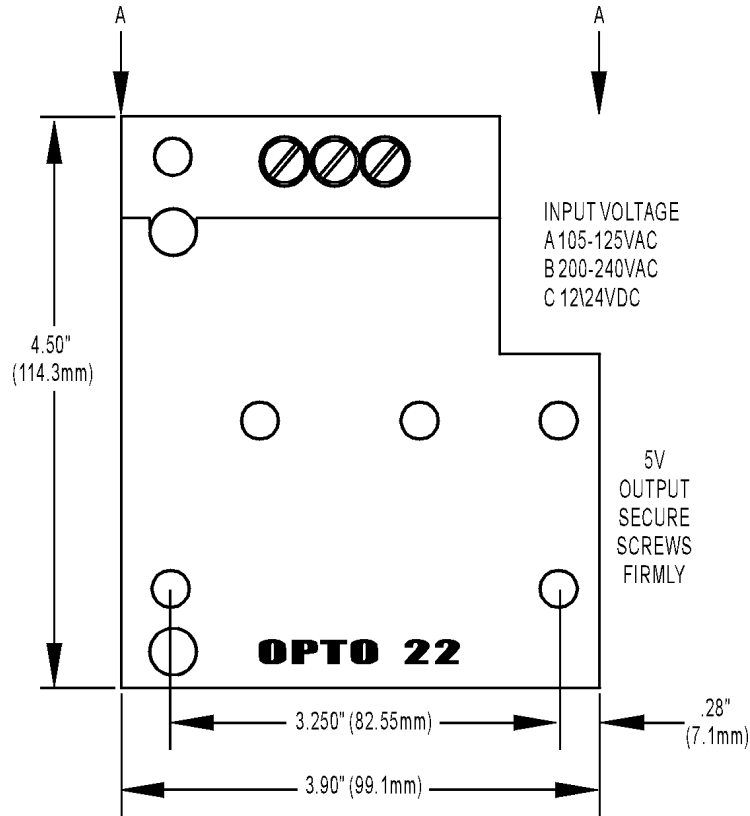

Products

Opto 22 produces a broad array of reliable, flexible hardware and software products for industrial automation, remote monitoring, enterprise data acquisition, and machine-to-machine (M2M) applications.

SNAP Ethernet Systems

Based on the Internet Protocol (IP), SNAP Ethernet systems offer flexibility in their network connectivity and in the software applications they work with. The physical network may be a wired Ethernet network, a cellular wireless network, or a modem. A wide variety of software applications can exchange data with SNAP Ethernet systems, including:

- Opto 22's own ioProject™ suite of control and HMI software
- Manufacturing resource planning (MRP), enterprise management, and other enterprise systems
- Human-machine interfaces (HMIs)
- Databases
- Email systems
- OPC client software
- Custom applications
- Modbus/TCP software and hardware.



SNAP Ethernet system hardware consists of controllers and I/O units. Controllers provide central control and data distribution. I/O units provide local connection to sensors and equipment.

SNAP OEM Systems

Opto 22 SNAP OEM I/O systems are highly configurable, programmable processors intended for OEMs, IT professionals, and others who need to use custom software with Opto 22 SNAP I/O modules.

Linux® applications running on these systems can read and write to analog, simple digital, and serial I/O points on SNAP I/O modules using easily implemented file-based operations. Applications can be developed using several common development tools and environments, including C or C++, Java, and shell scripts.



M2M Systems

Machine-to-machine (M2M) systems connect your business computer systems to the machines, devices, and environments you want to monitor, control, or collect data from. M2M systems often use wireless cellular communications to link remote facilities to central systems over the Internet, or to provide monitoring and control capability via a cellular phone.

Opto 22's Nvio™ systems include everything you need for M2M—interface and communications hardware, data service plan, and Web portal—in one easy-to-use package. Visit nvio.opto22.com for more information.

Opto 22 Software

Opto 22's ioProject and FactoryFloor® software suites provide full-featured and cost-effective control, HMI, and OPC software to power your Opto 22 hardware. These software applications help you develop control automation solutions, build easy-to-use operator interfaces, and expand your manufacturing systems' connectivity.



Quality

In delivering hardware and software solutions for worldwide device management and control, Opto 22 retains the highest commitment to quality. We do no statistical testing; each product is made in the U.S.A. and is tested twice before leaving our 160,000 square-foot manufacturing facility in Temecula, California. That's why we can guarantee solid-state relays and optically-isolated I/O modules *for life*.

Product Support

Opto 22's Product Support Group offers comprehensive technical support for Opto 22 products. The staff of support engineers represents years of training and experience, and can assist with a variety of project implementation questions. Product support is available in English and Spanish from Monday through Friday, 7 a.m. to 5 p.m. PST.

Opto 22 Web Sites

- www.opto22.com
- nvio.opto22.com
- www.internetio.com (live Internet I/O demo)

Other Resources

- OptoInfo CDs
- Custom integration and development
- Hands-on customer training classes.



About Opto 22

Opto 22 manufactures and develops hardware and software products for industrial automation, remote monitoring, enterprise data acquisition, and machine-to-machine (M2M) applications. Using standard, commercially available Internet, networking, and computer technologies, Opto 22's input/output and control systems allow customers to monitor, control, and acquire data from all of the mechanical, electrical, and electronic assets that are key to their business operations. Opto 22's products and services support automation end users, OEMs, and information technology and operations personnel.

Founded in 1974 and with over 85 million Opto 22-connected devices deployed worldwide, the company has an established reputation for quality and reliability.